



## Model N252 EC Pendant and Recessed Pendant Extended Coverage Area Density Sprinklers for Storage and Extra Hazard Applications

### Model N252 (SIN RA0842) Nominal K-Factor = 25.2

#### Features

1. Provides maximum coverage areas up to 14 ft. (4,27 m) by 14 ft. (4,27 m) 196 ft<sup>2</sup> (18,21 m<sup>2</sup>).
2. Can be installed recessed below finished ceilings with 1/2" (13 mm) adjustment. Available in brass, chrome, black plated and white polyester coated finishes.
3. 165 °F (74 °C) and 212 °F (100 °C) temperature ratings.
4. Listed by Underwriters' Laboratories Inc, Underwriters' Laboratories for use in Canada and Factory Mutual.
5. cULus Listed for unobstructed or non-combustible obstructed construction.



N252 EC Pendant

N252 EC Recessed Pendant  
(UL approved only)

#### Listings and Approvals

Listed by Underwriters' Laboratories Inc., UL certified for Canada (cULus) and FM Approved (**Pendant only**) as a storage sprinkler. NYC MEA 258-93-E

#### UL Listing Categories

Sprinklers, Automatic & Open  
Sprinklers for Storage Protection (Area/Density)

#### UL Guide Number

VNIV

#### US Pat. No. 7,624,812

#### Product Description

The Models N252 EC Pendant and Recessed Pendant Sprinklers are control mode, extended coverage sprinklers for storage and extra hazard density/area applications. This includes protection of the storage and display of Class I through Class IV commodities, non-expanded Group A Plastics, and non-expanded, exposed Group A Plastics in retail stores. The Model N252 EC sprinklers offer maximum coverage areas up to 14 ft by 14 ft (196 ft<sup>2</sup>), which is almost twice of that provided by standard coverage sprinklers. This offers the advantage of decreasing the number of required sprinklers, reducing labor and material costs.

#### Operation

The Reliable Model N252 Extended Coverage Pendant and Recessed Pendant Sprinklers utilize a levered fusible alloy solder link. When the rated temperature is reached, the solder melts and the two link halves separate allowing sprinkler to operate and water to flow.

## Installation

Model N252 sprinklers are to be installed as shown. Model FP escutcheons, illustrated herewith, are the only recessed escutcheons to be used with Model N252 EC Recessed Pendant Sprinklers. Use of any other recessed escutcheon will void all approvals and warranties. When handling sprinklers, hold sprinklers only on frame arms and do not apply any force on the link assembly. For installing Model N252 EC pendant and recessed pendant

sprinklers use only the Model N wrench (ref. Fig. 3). Use of wrenches other than that specified may damage these sprinklers. Sprinklers should be tightened between 22 to 30 ft. - lbs. (29,8 - 40,7 Nm) torque. Sprinklers not tightened to recommended torque may cause leakage or impairment of the sprinklers. Damaged sprinklers must be replaced immediately.

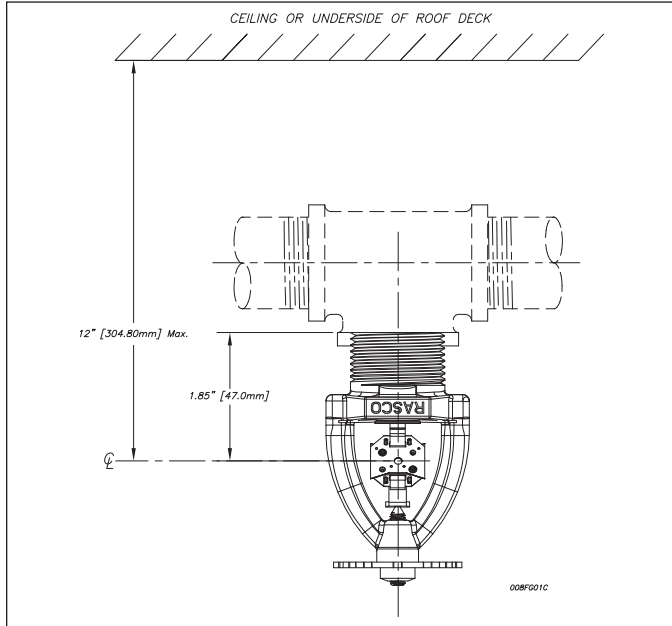

Fig. 1  
Model N252 EC Pendant

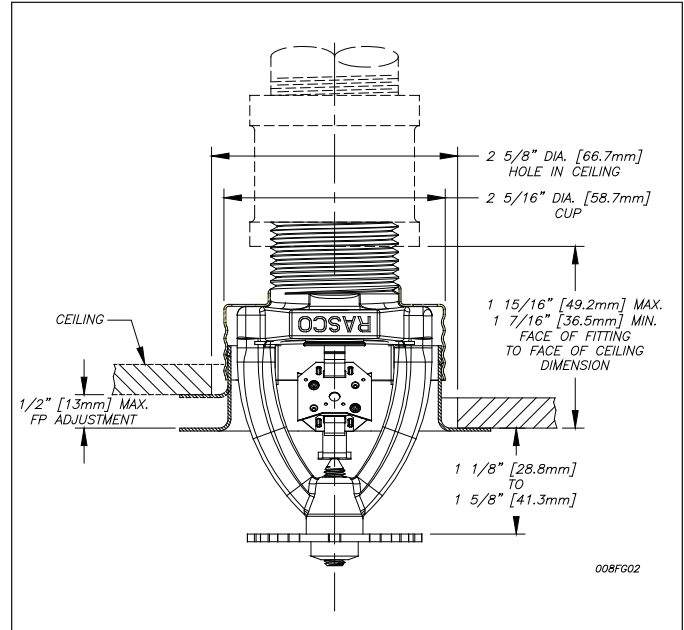

Fig. 2  
Model N252 Recessed EC Pendant/ FP

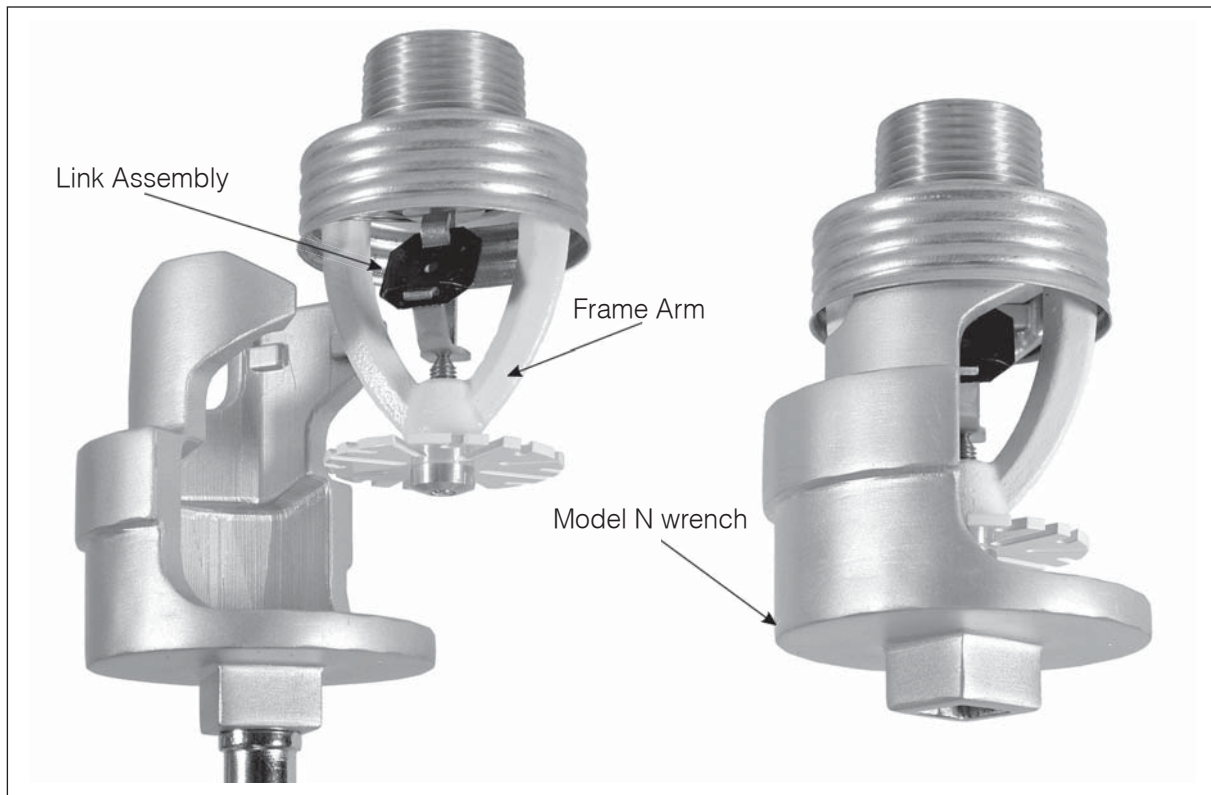

Fig. 3  
Model N Wrench

## Technical Data

Sprinkler Model	Type	Temperature Rating		Maximum Ambient Ceiling Temp.		Nominal K-Factor GPM/psi (LPM/bar) <sup>½</sup>	Orifice Size	Thread Size	Sprinkler Ht. Inch (mm)	Sprinkler Identification Number (SIN)
		°F	°C	°F	°C					
N252 EC	Pendent/ Recessed Pendent	165	74	100	38	25.2 (363)	1 inch	1" NPT (R1)	3.6 (91,5)	RA0842
		212	100	150	66					

### Design Criteria for UL and C-UL

The Models N252 EC Pendent and Recessed Pendent Sprinklers are cULus Listed standard response control-mode, extended coverage density/area sprinklers for installation in accordance with the extended coverage pendent spray sprinkler criteria of NFPA 13, or other applicable NFPA standards, when used in combination with the following guidelines:

- Protection for extra hazard and high-piled storage occupancies using NFPA 13 density/area criteria.
- Suitable for use in wet pipe systems, and in dry-pipe and preaction systems as specifically allowed for pendent sprinklers in NFPA 13.
- cULus Listed for “unobstructed” or non-combustible “obstructed” construction. Given that the Model N252 EC sprinklers are specifically listed for noncombustible obstructed construction, they may be installed within trusses or bar joists having noncombustible web members greater than 1 inch (25.4 mm) when applying the “Four Times Rule” as defined in NFPA 13 under “Obstructions to Sprinkler Discharge Pattern Development.”
- Maximum area of coverage per sprinklers is 196 ft<sup>2</sup> (18.2 m<sup>2</sup>); minimum area of coverage is 100 ft<sup>2</sup> (9.3 m<sup>2</sup>). Maximum spacing between sprinklers is 14 ft (4.3 m); minimum spacing between sprinklers is 10 ft (3.1 m).
- Minimum flow requirement is based on the design density applied over the actual area of coverage per sprinkler. Example 1, a design density of 0.43 gpm/ft<sup>2</sup> (17.5 mm/min) applied over 14 ft x 14 ft (4.3 m x 4.3 m) spacing, or 196 ft<sup>2</sup> (18.2 m<sup>2</sup>), would require a minimum sprinkler design flow rate and pressure of 84.3 gpm (319.2 L/min) at 11.2 psi (0.77 bar). Example 2, a design density of 0.43 gpm/ft<sup>2</sup> (17.5 mm/min) applied over 14 ft x 12 ft (4.3 m x 3.7 m) spacing, or 168 ft<sup>2</sup> (15.6 m<sup>2</sup>), would require a minimum sprinkler design flow rate and pressure of 72.2 gpm (273.3 L/min) at 8.2 psi (0.57 bar).
- Maximum working pressure - 175 psi (12.1 bar).
- Minimum end head pressure - 7 psi (0.5 bar).

- The minimum clearance between the deflector and the top of storage is 3 ft. (0,92m). For clearances of 3 ft. (0,92m) up to 4 ft. (1,21m), the minimum design pressure is 22 psi (1,52 bar). For clearances of 4 ft. (1,21m) and greater, the minimum design pressure is established by the minimum flow requirement (however, the pressure can never be less than 7 psi (0,48 bar)).
- Available temperature ratings are Ordinary, 165 °F (74 °C) and Intermediate, 212 °F (100 °C). Selection of temperature rating is based on the expected maximum ambient temperature exposure, or in accordance with the high-piled storage density/area curve requirements specified in Chapter 12 of the 2002 edition of NFPA 13. In accordance with the listing of the sprinkler, the density curves normally associated with high temperature rated sprinklers [286°F (141°C)] may be used with either the ordinary or intermediate temperature rating of the N252 EC sprinklers.
- The obstruction criteria in NFPA 13 for Extended Coverage Pendent Sprinklers shall be used for the locating and positioning Model N252 EC sprinklers relative to obstructions.

### Design Criteria for FM

The Model N252 EC Pendent Sprinklers are FM approved to be utilized in accordance with the following guidelines:

- FM approved for installations governed by data sheets 2-0 and 8-9.
- FM Global considers this a “Quick Response” extended coverage storage sprinkler.

### Maintenance

The Models N252 EC Pendent and Recessed Pendent Sprinklers should be inspected and the sprinkler system maintained in accordance with NFPA 25, and local jurisdictional requirements. Do not clean sprinklers with soap and water, ammonia, or any other cleaning fluids or solvents. Remove dust by using a soft brush or gentle vacuuming. Remove any sprinkler that has been painted (other than factory-applied) or otherwise altered after leaving the factory. A stock of spare sprinklers should be maintained to allow quick replacement of damaged or operated sprinklers. Prior to installation, sprinklers should be maintained in the original cartons and packaging until used to minimize the potential for damage to sprinkler that would cause improper operation or non-operation.

# Reliable...For Complete Protection

Reliable offers a wide selection of sprinkler components. Following are some of the many precision-made Reliable products that guard life and property from fire around the clock.

- Automatic sprinklers
- Flush automatic sprinklers
- Recessed automatic sprinklers
- Concealed automatic sprinklers
- Adjustable automatic sprinklers
- Dry automatic sprinklers
- Intermediate level sprinklers
- Open sprinklers
- Spray nozzles
- Alarm valves
- Retarding chambers
- Dry pipe valves
- Accelerators for dry pipe valves
- Mechanical sprinkler alarms
- Electrical sprinkler alarm switches
- Water flow detectors
- Deluge valves
- Detector check valves
- Check valves
- Electrical system
- Sprinkler emergency cabinets
- Sprinkler wrenches
- Sprinkler escutcheons and guards
- Inspectors test connections
- Sight drains
- Ball drips and drum drips
- Control valve seals
- Air maintenance devices
- Air compressors
- Pressure gauges
- Identification signs
- Fire department connection

---

The equipment presented in this bulletin is to be installed in accordance with the latest published Standards of the National Fire Protection Association, Factory Mutual Research Corporation, or other similar organizations and also with the provisions of governmental codes or ordinances whenever applicable. Products manufactured and distributed by Reliable have been protecting life and property for over 90 years, and are installed and serviced by the most highly qualified and reputable sprinkler contractors located throughout the United States, Canada and foreign countries.

---

Manufactured by

**Reliable**<sup>®</sup>

**The Reliable Automatic Sprinkler Co., Inc.**

(800) 431-1588

(800) 848-6051

(914) 829-2042

[www.reliablesprinkler.com](http://www.reliablesprinkler.com)

Sales Offices

Sales Fax

Corporate Offices

Internet Address



Recycled  
Paper

Revision lines indicate updated or new data.

EG. Printed in U.S.A. 12/13 P/N 9999970286